

W. H. DOANE.  
CIRCULAR SAWING MACHINE.

No. 303,923.

Patented Aug. 19, 1884.

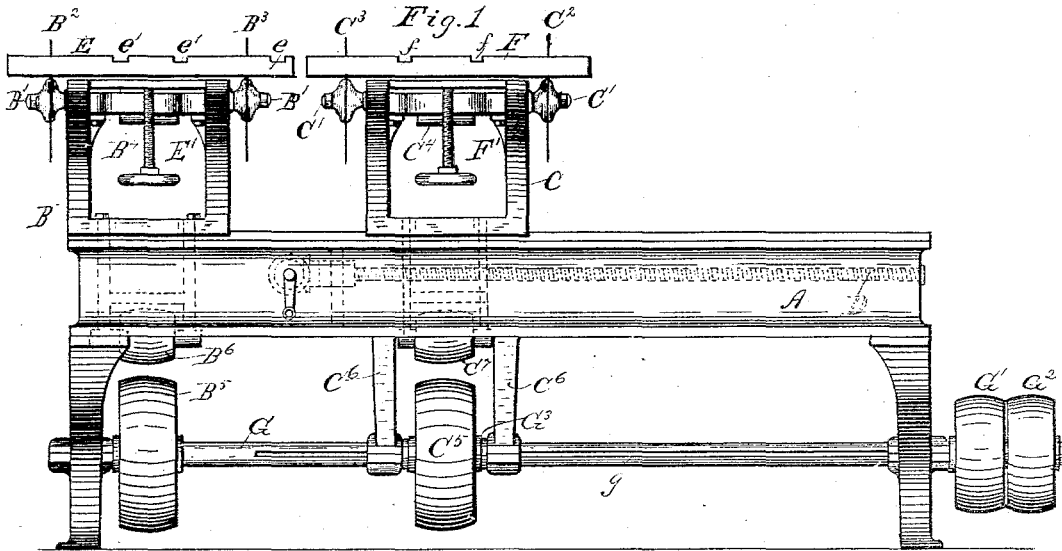
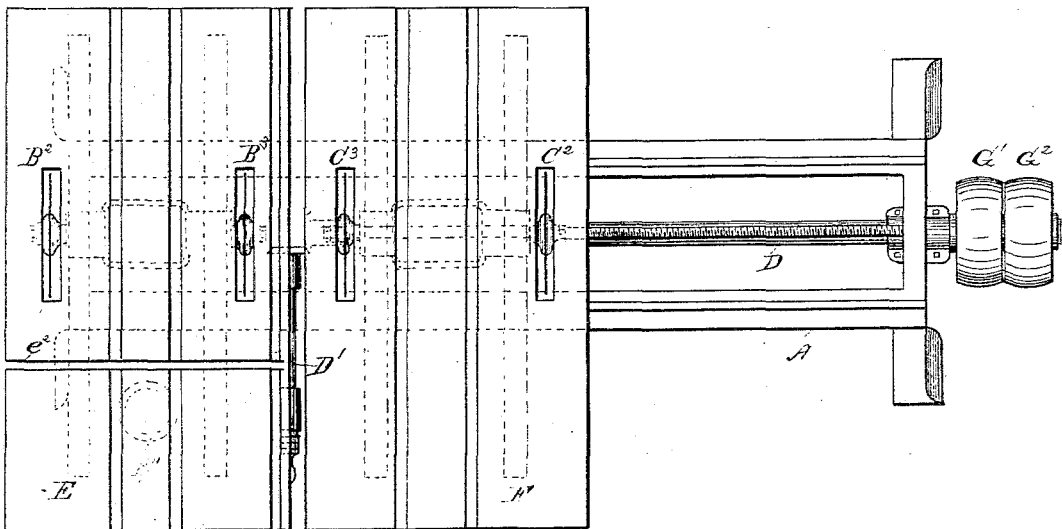

Fig. 3



Witnesses:  
*E. Walker*  
*Wm. Hamney*

Inventor:  
*William H. Doane*  
 by *his attorney*  
*Ed. Smith*

(No Model.)

2 Sheets—Sheet 2.

W. H. DOANE.  
CIRCULAR SAWING MACHINE.

No. 303,923.

Patented Aug. 19, 1884.

Fig. 4. Fig. 5.

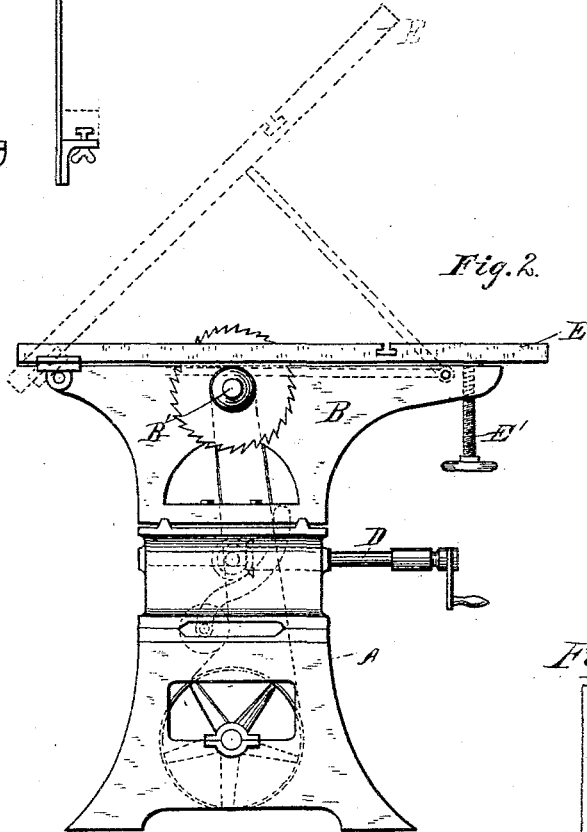
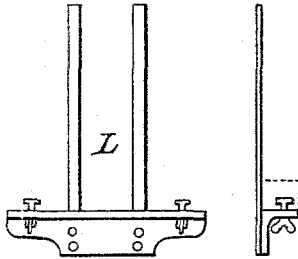

Fig. 2.

Fig. 11.

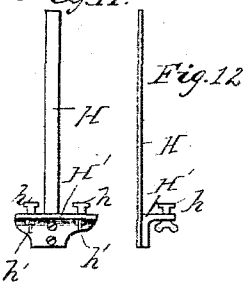

Fig. 12.

Fig. 9. Fig. 10.

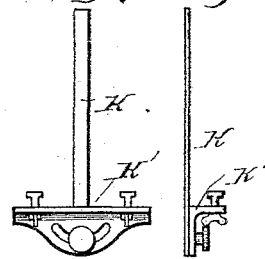

Fig. 6. M

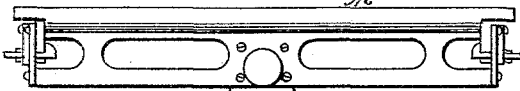

Fig. 7. M

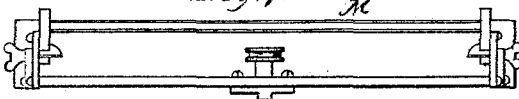
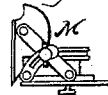
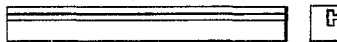

Fig. 8.



I Fig. 13. Fig. 14



Witnesses:

*E. Walker*  
*W. W. Hanway*

Inventor.

*William H. Doane*  
by his attorney  
*J. H. Hill*

# UNITED STATES PATENT OFFICE.

WILLIAM H. DOANE, OF CINCINNATI, OHIO.

## CIRCULAR SAWING MACHINE.

SPECIFICATION forming part of Letters Patent No. 303,923, dated August 19, 1884.

Application filed January 22, 1884. (No model.)

*To all whom it may concern:*

Be it known that I, WILLIAM H. DOANE, a citizen of the United States, residing at Cincinnati, in the county of Hamilton and State of Ohio, have invented certain new and useful Improvements in Duplex Crosscut-Saws; and I do hereby declare the following to be a full, clear, and exact description of the invention, such as will enable others skilled in the art to which it appertains to make and use the same.

This invention was devised to improve the circular sawing machine described in United States Letters Patent No. 244,335, granted to Daniel O. Striffler, July 12, A. D. 1881.

The improvement consists in providing each head-stock with a separate saw-arbor, and driving both saw-arbors from a single counter-shaft, which carries a fixed pulley for driving the saw-arbor of the fixed head-stock, and an adjustable pulley for driving the saw-arbor of the adjustable head-stock.

It further consists in journaling the adjustable pulley in hangers of the adjustable head-stock.

In order that the invention may be clearly understood, I have illustrated in the annexed drawings, and will proceed to describe, a form thereof which has been successfully used.

Figure 1 is a front elevation of the improved machine, the slides by which the stuff is fed to the saws being omitted. Fig. 2 is a side elevation of the same. Fig. 3 is a plan view thereof. Figs. 4 to 14 illustrate the slides and other appliances used for feeding and guiding and gaging the stuff.

The same letters of reference indicate identical parts in all the figures.

The different parts of the machine are supported on a frame or stand, A, the top of which has the form of the shears of a lathe. The stationary or fixed head-stock B is securely bolted on one end of these shears, while the adjustable head-stock C is so mounted that it may be slid on the shears by the operation of a screw-shaft, D, which is journaled in bearings on the shears beneath the head-stock C, and engages a nut formed or fixed on said head-stock. The inner end of the screw-shaft carries a bevel-wheel, which meshes with a bevel-wheel on a cross-shaft, D', which projects toward the front of the machine, so that

it can be turned to adjust the head-stock C by the operator without leaving his position at the front of the machine. Head-stock B supports a saw-arbor, B', and head-stock C a similar saw-arbor, C'. These independent saw-arbors project through their bearings with both ends, so that a saw may be mounted on either end, or one at each end, as shown. The saws on arbor B' are marked B<sup>2</sup> and B<sup>3</sup>, respectively; and the saws on arbor C' are marked C<sup>2</sup> and C<sup>3</sup>, respectively. The fixed head-stock B carries a table, E, hinged thereto at the rear end, and supported near the front end upon an adjustable screw, E'. The adjustable head-stock C carries a similar table, F, hinged thereto at the rear end, and supported near the front end upon an adjustable screw, F'. These tables are provided with suitable slots, through which the saws project. Saw-arbor B' carries a pulley, B<sup>4</sup>, by which it is driven from the fixed pulley B<sup>2</sup>, secured to the counter-shaft G through the medium of a suitable belt, to the slack side of which a belt-tightener, B<sup>6</sup>, may be applied, as shown. The counter-shaft G is parallel with the shears, and supported in suitable bearings of the main frame as near the floor as practicable. One end of the counter-shaft projects far enough through its bearings for the reception of the usual fast-pulley G' and loose pulley G<sup>2</sup> for the driving-belt from a line-shaft. Saw-arbor C' carries a pulley, C<sup>4</sup>, by which it is driven from the adjustable pulley C<sup>5</sup> on the counter-shaft G through the medium of a suitable belt. This adjustable pulley is in this instance secured to a sleeve, G<sup>3</sup>, a longitudinal groove in which is engaged by an extended spline, g, on the counter-shaft. The ends of sleeve G<sup>3</sup> are journaled in hangers C<sup>6</sup> C<sup>6</sup>, formed on or rigidly secured to the adjustable head-stock C. Collars or shoulders are formed on the sleeve just inside the respective hangers, so that the sleeve with its pulley will partake of the adjustments of the adjustable head-stock, and the alignment of the pulleys C<sup>4</sup> and C<sup>5</sup> maintained at all times. It will also be observed that the use of the grooved sleeve and hangers provides for a support of the counter-shaft at the point from which the saw-arbor of the adjustable head-stock is driven, so that the shears can be made of very considerable length, to provide for cross-cutting long pieces

of stuff, and a correspondingly long and comparatively light counter-shaft used without danger from undue vibrations.

It is obvious that the sleeve  $G^3$  may be omitted where the pulley  $G^5$  is constructed with an elongated hub mounted directly on the splined counter-shaft and journaled with its ends in the hangers  $C^6$ . A belt-tightener,  $C^7$ , similar to the belt-tightener  $B^6$ , may be applied to the slack side of the belt, which drives pulley  $C^4$ , the frame of the belt-tightener being attached to the adjustable head-stock, so as to move therewith. Table E is provided on the outside of saw  $B^3$  with a longitudinal groove,  $e$ , adapted to receive a slide, H, which, when inserted in said groove  $e$ , is flush with the top of the table. To one end of this slide H is rigidly secured a knee,  $H'$ , the upright portion of which carries a couple of headed screw-bolts,  $h$ , provided with thumb-nuts  $h'$ . A bar, I, constructed with a longitudinal T-groove, can be attached to the knee  $H'$  by sliding it upon the headed bolts and then tightening the thumb-nuts. The slide H, with its attachments, constitute a carriage for feeding a piece of stuff to the saws to saw it off square at one or both ends to any desired length within the compass of the machine. In the use of this feed-carriage the bar I may extend from table E to rest with one end on table F. To saw off long pieces both saws  $B^3$  and  $C^3$  are removed. Shorter pieces can be sawed off simultaneously at both ends by the saws  $B^3$  and  $C^3$ , the adjustable head-stock being first shifted so as to make the distance between the said saws just equal to the length of the pieces of wood required. For miter-sawing the slide K, provided with the adjustable nut  $K'$ , is used. The table E is also provided with a pair of parallel longitudinal grooves,  $e' e'$ , between its saws, and the table F with a similar pair of parallel longitudinal

grooves,  $f f$ , between its saws. These pairs of grooves are adapted to receive the two-legged slide L, which may be used in cutting off pieces to a length equal to the distance between the saws  $B^2$  and  $B^3$  or the saws  $C^2$  and  $C^3$ . The table E is also provided with a cross-groove,  $e^2$ , for the reception of the tongue of a rip-saw gage, M.

All the saws are detachably secured to their respective arbors, and any one or more of them may be quickly removed and reattached without changing the position of the adjustable head-stock.

In attaching or removing a saw its table is tilted up, as shown in dotted lines in Fig. 2, being supported on folded struts while the change is being made.

I claim as my invention—

1. A circular sawing machine embodying the following instrumentalities, namely: first, a stationary frame; second, a fixed head-stock provided with a superimposed saw-table and with a saw-arbor beneath said table; third, an adjustable head-stock provided with an independent superimposed saw-table and with an independent saw-arbor beneath said table; fourth, a counter-shaft carrying a fixed pulley for driving the saw-arbor of the fixed head-stock and an adjustable pulley for driving the saw-arbor of the adjustable head-stock.

2. The combination, substantially as before set forth, of the adjustable head-stock provided with hangers, the counter-shaft, and the adjustable pulley on said counter-shaft arranged between and journaled in said hangers.

In testimony whereof I affix my signature in presence of two witnesses.

WILLIAM H. DOANE.

Witnesses:

J. A. CLARK,  
A. A. NEAVE.